

Muon Accelerator R&D Issues

Date: October 4, 2014 (Revised: October 6, 2014)

Introduction

A set of R&D issues have been identified which could ultimately enable deployment of muon accelerator capabilities to provide a precision source of neutrinos, i.e., a Neutrino Factory (NF), for neutrino oscillation experiments as well as high brightness muon beams for use in TeV-scale muon colliders (MC). Figure 1 shows the basic block diagrams for high intensity NF and/or MC capabilities, as developed by the US Muon Accelerator Program (MAP), highlighting the overlaps between the key elements of the two. These block diagrams offer a structured way in which to discuss the most significant R&D issues related to such capabilities:

- The Proton Driver combined with the Target/Front End systems are the basis of a **high intensity muon source**;
- The Cooling system can provide a **high brightness muon source**;
- **Fast Muon Acceleration** systems are required to produce beams of these unstable particles with useful energies for high energy physics applications;
- **Muon Storage Rings** fall into two distinct categories: decay rings to provide precision neutrino sources and collider rings to provide high luminosity collisions at the multi-TeV energy scale.

A number of technology and beam physics challenges exist for each of these systems. Research efforts over the last two decades have shown that solutions to many, if not most, of the challenges are within reach. However, several key research topics are worthy of ongoing investment if the US accelerator research effort is to maintain a realistic option to deploy such capabilities, as warranted by the physics needs, in the future.

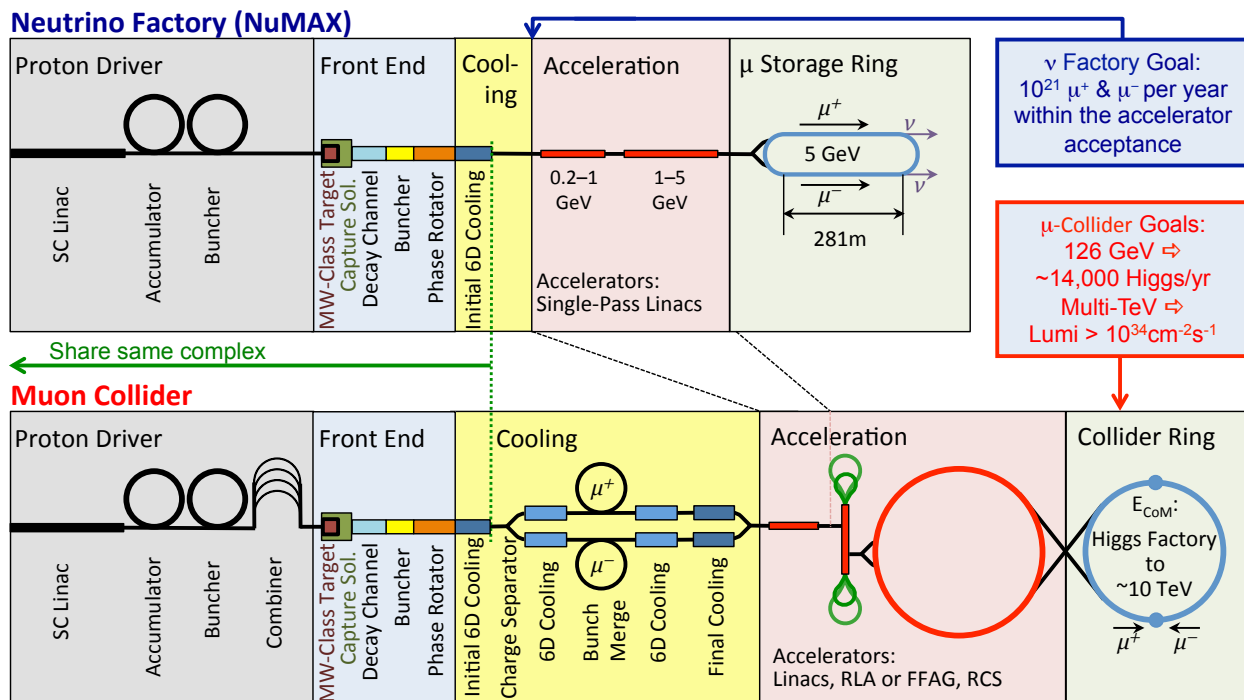

Figure 1: High-level block diagrams for deploying Neutrino Factory and/or Muon Collider capabilities along with the potential overlaps of a complex supporting both capabilities.



High Intensity Muon Sources

The only method that has been identified for muon production, which is capable of providing the high intensities required for long baseline neutrino oscillation experiments and/or colliders, is tertiary production from a multi-GeV proton beam striking a target. For NF and MC applications, these beams must be formatted in bunches with lengths of a few nanoseconds striking the target with repetition rates of roughly 10-60 Hz. Viable concepts exist for all of the key elements of the proton driver, although further evaluation of H^- stripping options (which has never been demonstrated at multi-GeV proton energies) is desirable. Evaluation of target damage issues, both for solid and liquid target options, from proton beams with the pulse format described above are necessary to refine our understanding of the ultimate performance limits for muon production.

A primary issue for a muon accelerator front end is the ability of the transport channel to transmit the secondary pions while filtering out both residual proton beam and unwanted interaction products from the target. Simulating methods to ensure transmission of the desired beam, while mitigating the energy deposited by the unwanted target byproducts, represents a key issue for enabling very high intensity muon beams. A second issue is to understand how effectively a muon beam can be manipulated by a buncher and phase rotation system when the required RF system must work in the guide field of a solenoid transport channel. A key demonstration from the MuCool Test Area (MTA) has been the successful operation of high-pressure gas-filled cavities in magnetic field and with a high intensity beam. Thus a technology solution exists for the buncher and phase rotation systems. A simulation campaign, originally planned for the next two years within MAP, would enable a clear specification of the likely performance limits of a high intensity muon source based on a proton driver.

It should be noted that alternative muon production techniques have been proposed based on the interactions of high energy photons with a plasma and interactions of positron beams with either plasma or material targets. These techniques offer a potential path to polarized muon sources with relatively low emittance (see, for instance, presentations from working group 7 of this year's Advanced Accelerator Concepts Workshop, <https://aac2014.stanford.edu>), but do not appear capable of achieving the intensities required for NF and MC applications. Nonetheless, they may be of interest for lower intensity physics applications. A final issue for the proton-based source is adjustment of the capture parameters to provide varying degrees of polarization in the resulting muons.

Summary of R&D Topics:

- [Proton Driver 1] Simulation studies of H^- stripping concepts for multi-GeV beams (including the laser-stripping option);
- [Proton Driver 2] Design of a combiner system for simultaneous delivery of multiple beams on target as required for a muon collider;
- [Target 1] Simulation studies to evaluate solid target damage from short (few nanosecond) proton pulses (10s of Hz operation with 1-2 MW total power) ;
- [Target 2] Simulation studies to evaluate the interactions of short proton pulses with liquid metal jet targets (~10-60 of Hz operation with multi-MW total power);
- [Front End 1] Simulations to characterize the beam control, transmission and losses in a muon accelerator front end system and to specify the performance limitations imposed by energy deposition issues;
- [Front End 2] Simulations to understand and optimize the performance of a buncher and phase rotator system utilizing gas-filled RF cavities;
- [Front End 3] Simulations to understand the performance trade-offs between polarization and intensity in a proton-based muon source;
- [General Source] Continued studies of alternative muon production techniques, which could yield polarized muon beams.

High Brightness Muon Sources

A high brightness muon source requires cooling of the high intensity, but hot, beams described in the preceding section. Figure 2 shows the evolution of the transverse and longitudinal emittance of the muon beam through the front end and ionization cooling stages, as envisioned by MAP. Analysis by the Muon Accelerator Staging Study (MASS) has led to the conclusion that the initial step in a muon emittance cooling channel should provide 6D cooling (labeled Initial Cooling in Figure 2) to optimize the beam emittance for the acceptance of any subsequent acceleration stage (a major cost driver in a real machine). The resulting beams would be suitable for NF applications, such as the NuMAX concept, as well as improved sources for experiments such as those probing charged lepton flavor violation. Subsequent 6D Cooling stages would take the beam to a space-charge-limited longitudinal emittance and significantly reduced transverse emittance. This point would be well-suited for a muon collider Higgs Factory with sufficiently small beam energy spread ($\sim 2\text{-}2.5$ MeV) to directly measure the Higgs width. A subsequent Final Cooling stage would exchange transverse and longitudinal emittance to achieve the small transverse emittance required for multi-TeV MC operation with high luminosity ($\sim 10^{34}\text{-}10^{35}$ cm⁻²s⁻¹ for 1-10 TeV).

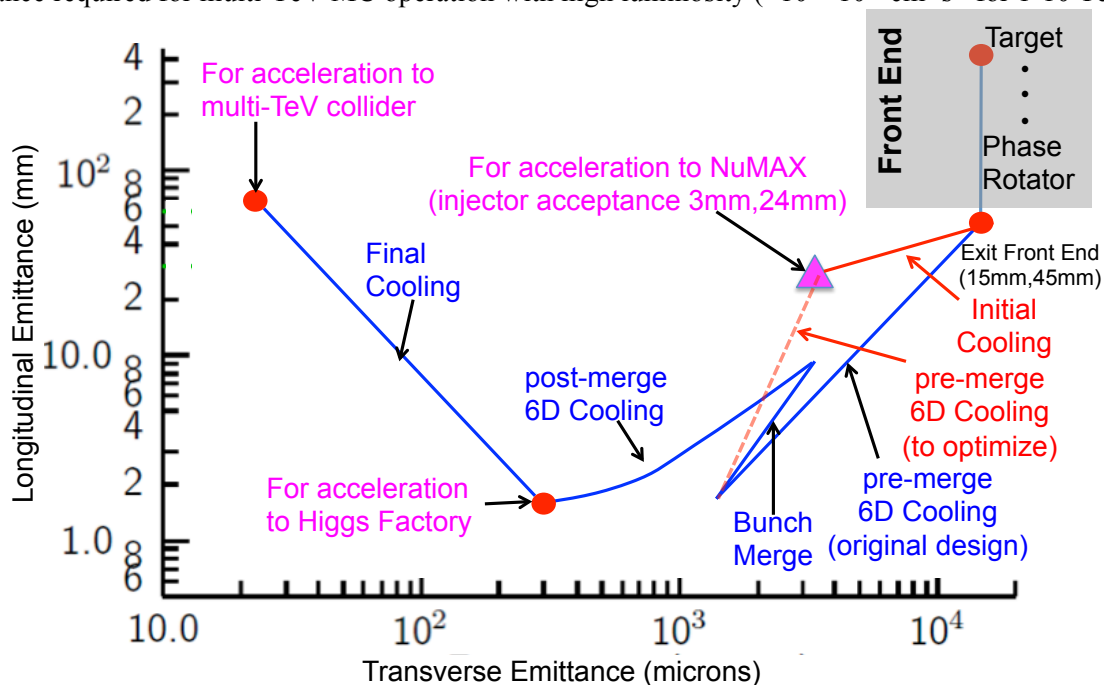

Figure 2: Emittance evolution for a proton-based muon source as envisioned in the design concepts developed by the Muon Accelerator Program.

MAP has defined the basic beam optics concepts for each of the above cooling stages. The program has also implemented the high performance computing tools required to efficiently simulate the beam physics issues that will determine the performance limits of these channels. A simulation effort to complete the evaluation of the performance limits of these concepts, due to collective effects and other issues such as beam-plasma interactions, would complete a major step forward in our understanding of cooling channel options for future muon accelerator capabilities. In a highly constrained budget environment, such an effort could logically be handled sequentially to complete the evaluation of the earlier cooling stages first. Such an approach is also supported from the beam physics viewpoint in that the performance requirements for each successive stage are closely tied to the output achieved from the preceding stage. For example, the final transverse emittance that can be achieved in the 6D cooling sections will have a strong impact on the requirements for the Final Cooling stage.

Technology R&D represents another fundamental element towards the development of a high brightness muon source. In particular, RF cavities must operate in the high magnetic fields required to achieve the cooling channel lattice. As already noted, the MTA R&D program into high gradient RF operation in



US Muon Accelerator Program Note

high magnetic fields has demonstrated the technique of high-pressure gas-filled cavities for operation in this environment. The effort is poised to conduct a series of experiments to characterize the fundamental surface preparation and material effects on breakdown performance of RF cavities operating in vacuum.

Summary of R&D Topics:

- [Initial Cooling] Evaluation of the expected performance of an Initial Cooling channel which could support NF and other physics applications (e.g., CLFV experiments);
- [6D Cooling 1] Simulation studies to evaluate the beam physics effects that would impact the performance of a gas-filled RF ionization cooling channel, in particular, full evaluation of the beam-plasma interaction;
- [6D Cooling 2] Simulation studies to evaluate the beam physics effects that would impact the performance of a vacuum RF ionization cooling channel;
- [Final Cooling] Simulation studies to evaluate the performance of a Final Cooling channel as required to provide low transverse emittance beams for a high luminosity TeV-scale muon collider;
- [RF R&D 1] R&D to characterize the RF cavity operation in magnetic fields – in particular, to complete the present research program into cavity materials and surface preparation and their impact on breakdown performance and longevity of vacuum RF cavities;
- [RF R&D 2] R&D to validate the viability and performance specifications of compact, high-pressure gas-filled cavities for operation in magnetic fields and in the presence beam-induced plasma.

Fast Muon Acceleration Systems

Rapid acceleration systems are required to take muons to the energies required for NF and MC applications. Within MAP, the MASS effort has reached the conclusion that low energy acceleration can best be achieved by providing a suitably cooled beam to a single-pass linear accelerator. An additional cost-saving feature is that this linac can be utilized for dual-species acceleration to provide acceleration for both the muon beams as well as the proton beams from which they are produced. While such a linac concept is reasonable for acceleration to energies suitable for a neutrino factory such as NuMAX (i.e., storage rings with energies <10 GeV), acceleration to higher energies requires multiple pass acceleration concepts. For acceleration to beam energies of several tens of GeV, Recirculating Linacs (RLAs) offer an efficient scheme. The RLAs can employ multiple return arcs or potentially broad bandwidth multi-pass arcs. For acceleration into the hundreds of GeV or TeV range, hybrid rapid cycling synchrotrons (RCS), with a combination of fixed and varying field magnets, are the technology choice determined by MAP. These accelerators require fast, high-field magnet systems that can operate at frequencies ≥ 400 Hz. While operation of simple test magnets with the necessary peak fields in this frequency range has been shown, full-scale demonstrations, including the necessary power supply system, are yet to be attempted.

While the basic acceleration concepts are now well-defined for the full range of energies envisioned for high-energy muon accelerator applications, further evaluation of the performance of these acceleration systems is required. For instance, a full study of emittance diluting effects during beam transport in the wide bandwidth RLA arcs and in the rapid-cycling synchrotron optics has not yet been carried out.

Summary of R&D Topics:

- [Linac] Simulations to evaluate the expected performance of the proposed initial single-pass linac system;
- [RLA] Simulations to evaluate beam stability and emittance diluting effects in RLAs and develop the necessary magnet quality specifications;
- [RCS] Simulations to evaluate beam stability and emittance diluting effects in RCS accelerator systems and develop the necessary magnet quality specifications;
- [RCS Magnet] Demonstration of a full-scale 400 Hz Rapid Cycling Magnet prototype.



Muon Storage Rings

Within the MAP effort, concepts have been defined for NF storage rings, ranging from the nuSTORM ring for a short baseline NF to the NuMAX concept for a long baseline NF directed from Fermilab to the Sanford Underground Research Facility (SURF). A low energy muon storage ring, as a precision neutrino source to help calibrate our knowledge of neutrino cross sections, represents a potential near- to mid-term need to control the systematics in long baseline superbeam experiments to the <1% level.

For colliders, significant progress was made in establishing working optics solutions for rings with center-of-mass energies from the Higgs to the multi-TeV scale. Magnet and component shielding concepts have been developed for the collider rings where the muon beams typically decay with a time constant on the order of 10^3 turns. Furthermore, the modest detector effort that has worked alongside the MAP Machine-Detector Interface (MDI) effort has shown that viable solutions exist to control the impact of backgrounds in the detector for effective physics analysis.

Summary of R&D Topics:

- [NF1] Studies of cost-effective low energy muon storage ring options to strengthen the long baseline neutrino physics program;
- [NF2] Simulations to characterize the performance of a long baseline NF based on updates to the performance specifications of the front end, cooling and acceleration systems;
- [Collider1] Tracking studies to characterize the performance of the proposed collider and their sensitivity to collective effects;
- [Collider2] Exploration of lattice designs for a >5 TeV center-of-mass collider ring which limit straight sections in the ring. This will minimize ionizing radiation from reactions of decay neutrinos where they exit the earth's surface, which will otherwise limit the maximum operating energy for a collider;

Conclusion

The preceding sections identify a set of research topics that are considered fundamental issues for muon accelerator applications for high energy physics. Thus they are potentially suitable for General Accelerator R&D (GARD) support. Given the simulation infrastructure presently in place as part of the MAP effort, significant progress could be made on most of the simulation topics with 1-2 FTE-yrs per topic of effort by a junior researcher who is suitably supervised by a more senior member of the present MAP team. The list of potential topics does not include technology R&D efforts that are being pursued elsewhere – for instance, high field magnet development (this includes the development of very high field, 30T class, solenoids for user magnets, which are very similar to the specifications of those presently envisioned for the Final Cooling stage).

The technology R&D items that are included in the above lists are those for which muon accelerator applications have unique technology pull. Thus the RF in magnetic field R&D program, which will be supported for the next 1.5 years as part of the MAP ramp-down, and the demonstration of a high frequency rapid cycling magnet system have a unique role to play. It should be noted that the current generation of experiments planned for the RF in magnetic field studies require roughly 2.5 years to complete, while MAP support will only be available for the first portion of that period. Thus, even limited General Accelerator R&D funding for roughly half a year of effort each in FY16 and FY17 could yield significant benefit to our understanding of the fundamental issue of cavity breakdown in magnetic fields.

A final issue is the prioritization of the various topics. MAP had intended to explore all of the above issues over the course of the next 3-4 years. In a budget-constrained environment, where the primary focus of the domestic program is on the long baseline neutrino (LBN) program, one possible approach would be to focus first on those topics that would: 1) support the LBN effort; 2) would enable the



US Muon Accelerator Program Note

development of next generation LBN capabilities; and 3) which would also be integral to any future collider option if found to be necessary based on future LHC results. Such an effort might focus on the topics labeled [Front End], [Initial Cooling], [6D Cooling], [RF R&D], [Linac] and [NF] in the above lists. Sometime in the next week, MAP managers in charge of the work in these areas plan to submit two white papers summarizing such a prioritization and more explicitly stating the resource estimates and intended research plan to the panel.